

THE
**MIDNIGHT
QUILT
SHOW**



SET THE TABLE PLACEMATS EPISODE

Brought to you by *Craftsy*

SET THE TABLE PLACEMATS

Designed by Angela Walters



boundless

FABRICS
BY CRAFTSY

Featured on
The Midnight Quilt Show
with Angela Walters!

Finished Size: 13" x 19 ½"

4 Placemats

FEATURED IN THIS EPISODE



Set the Table Placemats Kit,
Designed by
Angela Walters.
Kit includes everything you
need for your quilt top and
binding, plus the pattern.

SUBSCRIBE

Be sure to never miss an episode! Go to youtube.com/midnightquiltshow and click "Subscribe" to get fresh episodes delivered to your inbox.

#MIDNIGHTQUILTSHOW #FEELINGCRAFTSY

Join our Instagram community! Follow @CraftsyQuilts and @BeCraftsy for daily inspiration, then share your own projects to inspire your fellow makers. Use the hashtag #MidnightQuiltShow and #FeelingCraftsy so we can see what you've made (and re-share it, too)!



QUESTIONS OR COMMENTS?



Get in touch with our Customer Support team at CraftsyHelp.com
HAPPY MAKING!

TIPS FOR SUCCESS

- 1. WATCH THE EPISODE!**
See how Angela pieces and quilts these designs as she works her way through the quilt top. Go to youtube.com/midnightquiltshow and search for Set the Table Placemats.
- 2. GET THE DIAGRAMS**
See the next few pages for Angela's sketched quilting designs. These are a great starting point for quilting ideas-- whether you want to Turn In Early with something simpler, or stay Up All Night with more free-motion fun.
- 3. GET YOUR MACHINE READY**
Prepare for quilting success by ensuring that your machine needle is sharp. Are you experiencing breakage of your top thread, or skipped stitches? Do you hear a quiet popping sound when your needles move through the fabric? These are all signs that your needle is dull and it's time for a change.

Craftsy

CRAFTSY.COM

PATTERN INSTRUCTIONS

Supplies Needed

- One set of pre-cut 2 ½"-wide strips (shown in Boundless Collage Bittersweet)
- 1 ¼" yards fabric for backing
- 4 pieces of batting, cut 17" x 24" each

Cutting Instructions
From 8 - 2 ½" strips, cut: 40 - 2 ½" x 7 ½" pieces
From 7 - 2 ½" strips, cut: 40 - 2 ½" x 6 ½" pieces
From 5 - 2 ½" strips, cut: 40 - 2 ½" x 4 ½" pieces
Set aside 8 strips for binding
From the backing fabric, cut: 4 - 17" x 24" pieces

Row A Assembly

STEP 1

On the back of a 2 ½" x 7 ½" piece, draw a diagonal line from the top left at a 45° angle, as shown. Watch direction of the line so that it is exactly like the diagram. Following the diagram, lay out the drawn 2 ½" x 7 ½" piece, right sides together on a 2 ½" x 4 ½" piece. Sew on the line and press in the direction of the arrow. Trim the bottom two layers to ¼" seam allowance.

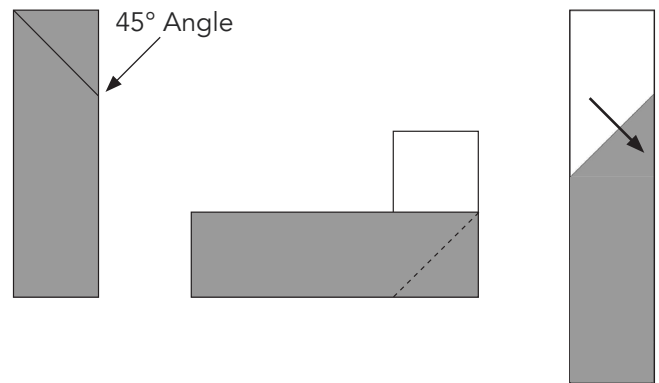

STEP 2

On the back of a 2 ½" x 6 ½" piece, draw a diagonal line from the top right at a 45° angle, as shown. Watch direction of the line so that it is exactly like the diagram. Lay the drawn 2 ½" x 6 ½" piece on the piece from step 2 as shown. Sew on the line and press in the direction of the arrow. Trim the bottom two layers to ¼" seam allowance. The strip should measure 2 ½" x 13 ½". Repeat to make five.

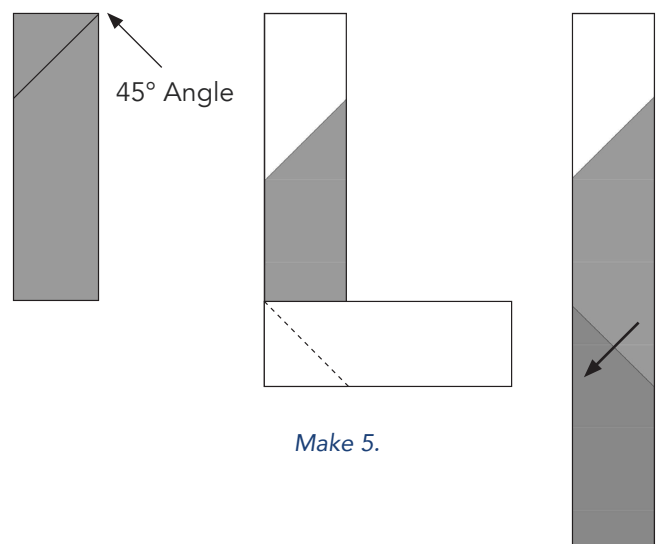

PATTERN INSTRUCTIONS

Row B Assembly

STEP 1

On the back of a 2 ½" x 7 ½" piece, draw a diagonal line from the top right at a 45° angle, as shown. Watch direction of the line so that it is exactly like the diagram. Following the diagram, lay out the drawn 2 ½" x 7 ½" piece, right sides together on a 2 ½" x 4 ½" piece. Sew on the line and press in the direction of the arrows. Trim the bottom two layers to a ¼" seam allowance.

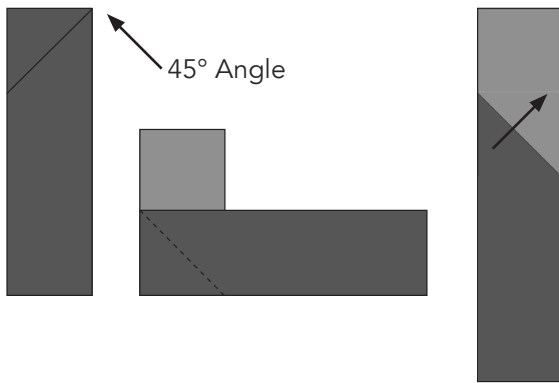

STEP 2

On the back of a 2 ½" x 6 ½" piece, draw a diagonal line from the top left at a 45° angle, as shown. Watch direction of the line so that it is exactly like the diagram. Lay the drawn 2 ½" x 6 ½" piece on the piece from step 2 as shown. Sew on the line and press in the direction of the arrows. Trim the bottom two layers to ¼" seam allowance. The strip should measure 2 ½" x 13 ½". Repeat to make five.

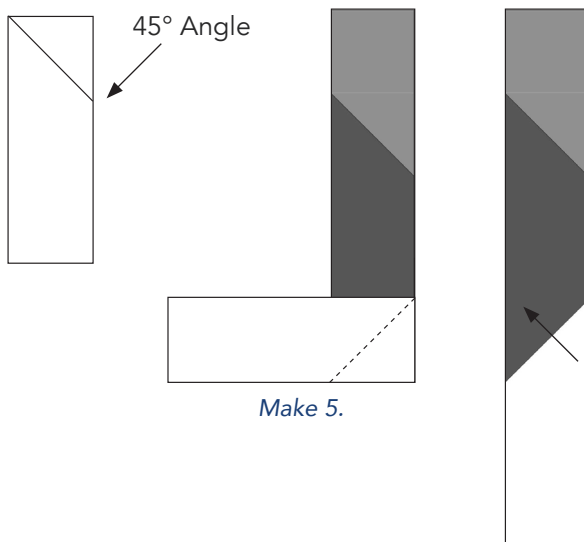

Assembly & Quilting As You Go

STEP 1

Layer backing fabric, wrong sides up. Place batting on top and smooth out. Optional: Spray-baste or pinbaste batting to backing to keep in place while sewing.

STEP 2

Lay a Row A strip face up on the batting, about 1" from the left side.



STEP 3

Place a Row B strip, on top of the Row A strip, right sides together, matching the edges. Sew along the right side using a ¼" seam allowance. Press towards the piece just added.

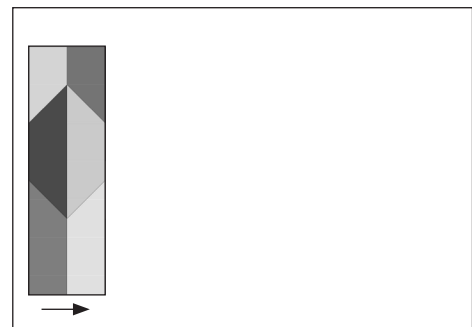
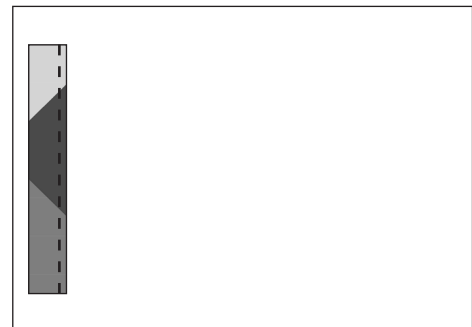

PATTERN INSTRUCTIONS

STEP 4

Lay a Row B strip, right sides together on the Row B piece you just sewed. Rotate the Row B strip so the 4 1/2" piece is at the bottom, per diagram. Sew using a 1/4" seam allowance along the right edge. Press towards the piece just added.

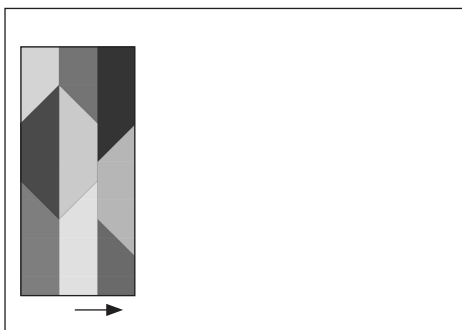
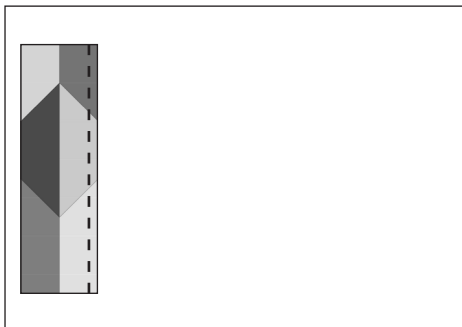

STEP 5

Continue by sewing Row A strip with the 4 1/2" piece at the bottom, per diagram. Press towards the piece just added.

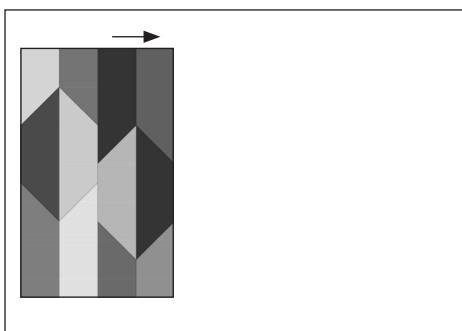

STEP 6

Repeat steps 2-5 to have a total of five each of Row A and Row B strips sewn on. Continue pressing towards the just added piece. Repeat to make four placemats.

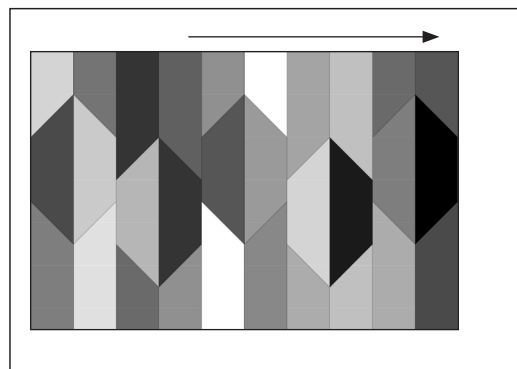

Finishing

STEP 1

Trim the placemat even around the edges. Join 2 - 2 1/2" strips to make binding and sew to the placemat to bind edges. Hand or machine stitch the binding down. Repeat for all four placemats.

SET THE TABLE PLACEMATS

Quilting Diagram

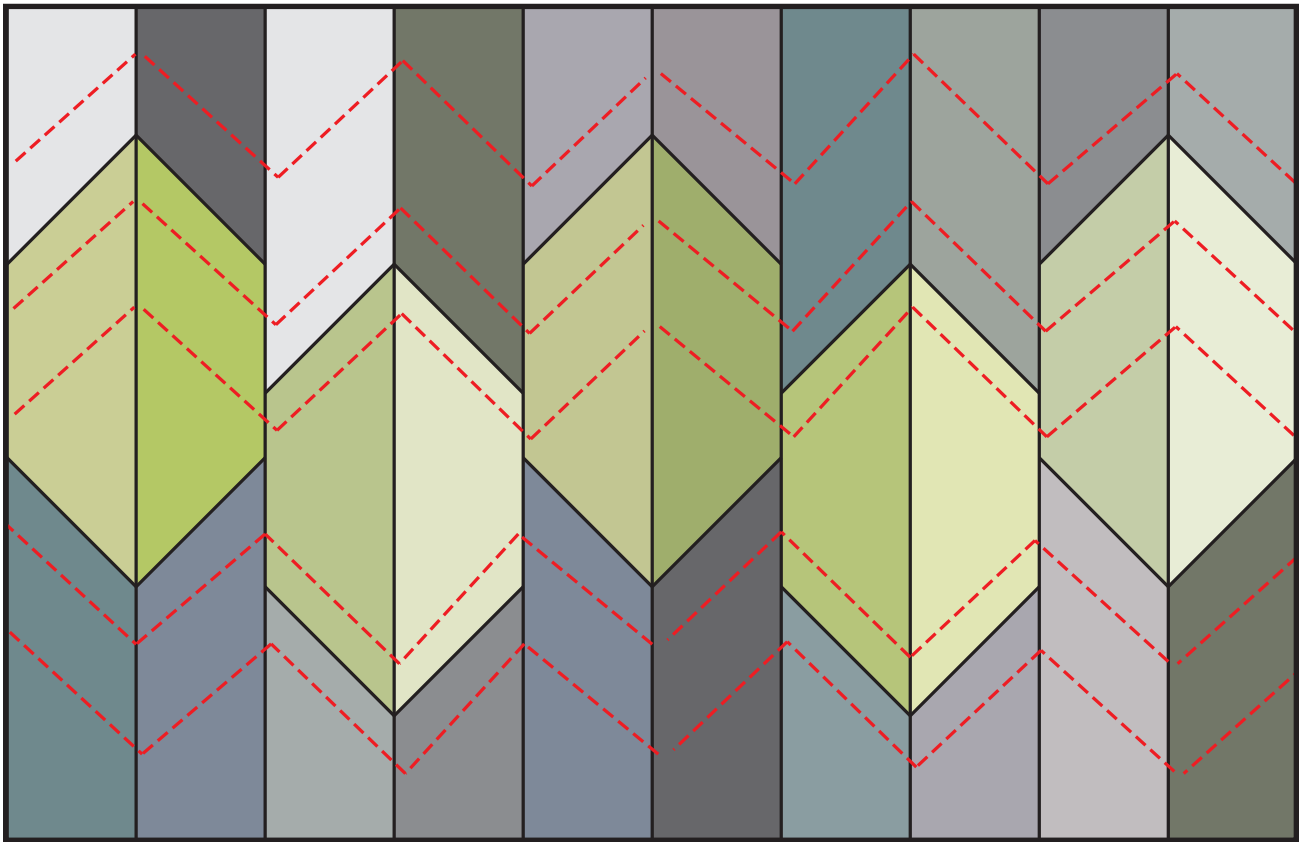

Turn in Early

Quilting as-you-go is one of the quickest ways to finish a project, so if you want to turn in early, you don't need to add any additional quilting to your placemats. That leaves more time for fun things like snacking or more piecing!

Up All Night

Although not required, you can always add a little more quilting! Use your walking foot to follow the piecing lines and echo the diamond shapes.

Brought to you by **Craftsy**